

CITY

PALFINGER PALIFT

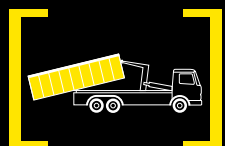

THE SMALL POWER-PACK



THE PERFECT HOOKLOADER FOR TRUCKS UP TO 7.5 TONS

The **CITY**, with its unique hook boom arrangement, allows the handling of various container lengths. Very easy to operate, the design of the **CITY** results in a low pick-up angle and offers an optimal ratio between lifting capacity and tare weight.

In addition to the well known areas of applications; such as recycling and handling Municipal waste containers, it is the ideal transport solution for handling a wide range of equipment on the lower capacity vehicles.

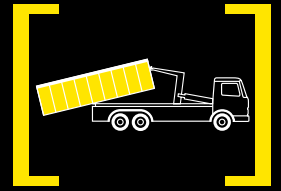

THE CITY CAN BE DEPLOYED IN AN EXTREMELY WIDE RANGE OF APPLICATIONS



TECHNICAL DATA: CITY

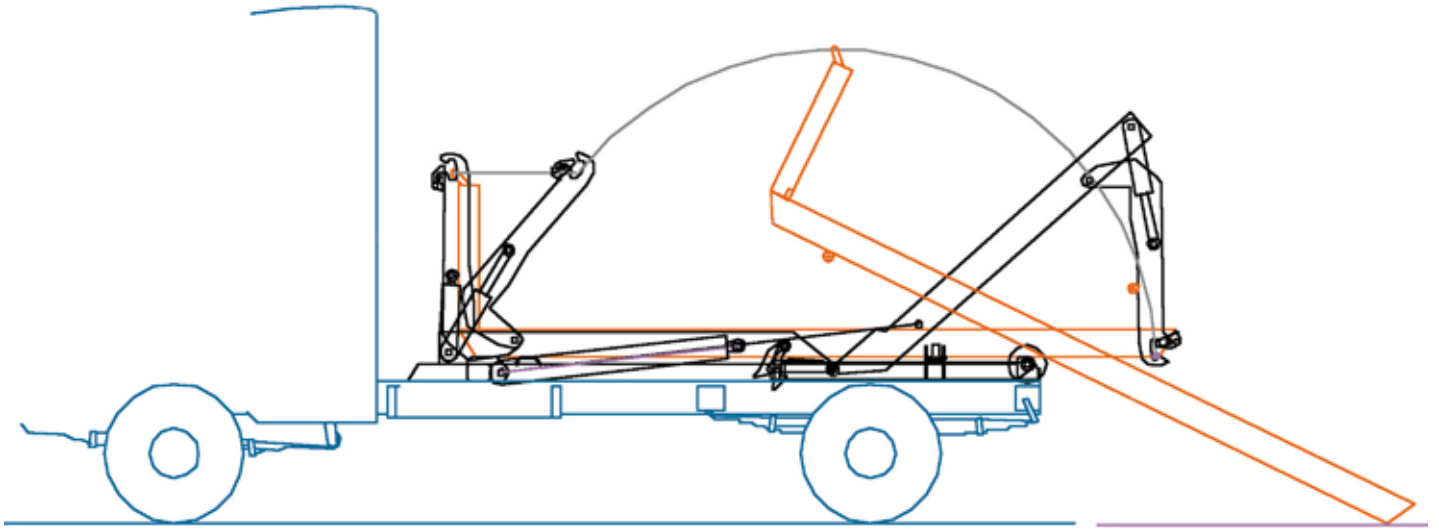

Model	Max. lifting capacity	Weight approx.	Inside Container length mm	Recommended truck total weight	Hook height mm
C 2	2 t	350 kg	2500 - 3500 mm	3 - 4 t	900 mm
C 3	3 t	380 kg	2500 - 3500 mm	4 - 5 t	900 mm
C 4	4 t	550 kg	3000 - 4000 mm	5 - 7.5 t	900 mm

- Weight depends on equipment and unit length
- Container length depends on locking system and unit length; the stated container lengths refer in each case to the shortest and longest unit length
- Lifting capacity depends on the container length, truck frame height and hook height

More than 35 years of experience in the manufacture of hookloaders along with 1500 service and sales outlets in more than 125 countries speak for the reliability of our products.

The equipment displayed is partly fitted with special equipment and therefore do not always correspond to the standard model. Country specific stipulations must be additionally adhered to.

